



DESIGNED FOR LOW VOLUME APPLICATIONS

2½ Gallons per Hour – 7 Quart Capacity

ECONOMICAL IN PRICE & SPACE!

The **SaniServ** model DF100 Frozen Beverage Freezer is the perfect addition to establishments wishing to offer their customers premium frozen beverages like margaritas and daiquiris. Economical in price and space, **DuraFreeze** offers the prospect for high profits and customer satisfaction.

SPACE SAVING

Small Footprint Design - SaniServ model DF100 offers frozen beverages in the smallest space saving equipment and design available! Owners and Operators can turn even the smallest of countertop space into a high profit center while enjoying lower indoor operating costs and providing the frozen beverages customers want!

EASY CLEANING AND OPERATION

Fewer Parts = Simplified Cleaning – SaniServ equipment is designed and built with the fewer parts to be disassembled, cleaned and sanitized than any other machine in the industry.

HIGH RETURN ON INVESTMENT

Increased Profits – SaniServ machines combine affordable efficiency with consistent product quality and fast quiet operation to insure customer satisfaction with high profit frozen beverages.

QUALITY DESIGN

Durability – SaniServ machines are built to achieve long and dependable life through simplicity of design. Every machine is shipped standard with a stainless steel exterior, durable construction, heavy-duty components and consistency systems.

Model DF100

Countertop
Frozen Beverage Machine
DuraFreeze



Made in USA

We reserve the right to change specifications and products design without notice. Such revisions do not entitle the buyer to corresponding changes, improvements, additions or replacements for previously purchased equipment



MODEL DF100

Counter Model Frozen Beverage/Cocktail Freezer

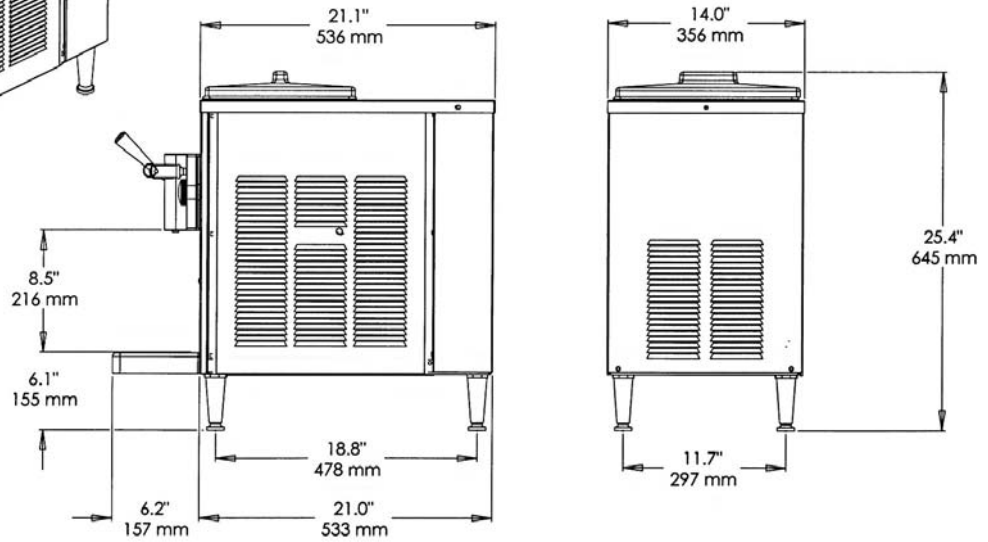
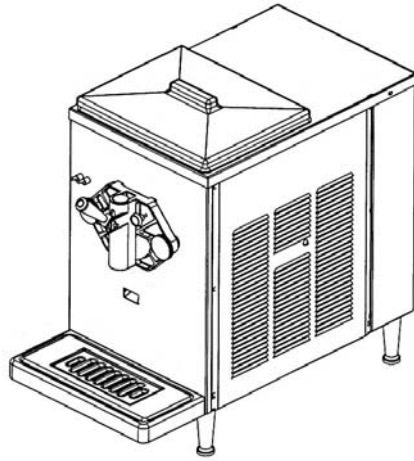

Minimum Wall Clearance
Both Sides and Back -
6 inches (152 mm)

ELECTRICAL				WIDTH	HEIGHT	DEPTH	WEIGHT	VOLUME
VOLTS	Hz	Ph.	Amps	INCHES (MM)	INCHES (MM)	INCHES (MM)	LBS. (Kg)	CU FT. (cu. m.)
115	60	1	15	14 (356)	25.4 (648)	21.1 (536)	145 (66)	
Shipping Specifications				22.5 (572)	31.5 (800)	34 (863)	172 (78)	8.6 (.24)

Specifications:

Cooling System:
Air Only

Dasher and Compressor Motor:
1/4 HP Dasher
1/3 HP Compressor

Refrigerant Type:
R404A

Listings:
UL, cUL, NSF

Features:

Evaporator and Mix Reservoir
Capacity:
7 Quarts (6.6 liters)

Dasher:
Heavy-Duty Stainless Steel with low friction scraper blades.

Controls:
Automatic consistency controls for improved product consistency.

Warranty:

Parts 90 days
Compressor 1 year
Labor 30 days

Options:

Tune Up Kit
Machine Stand
Custom Graphic